



# Richards-Wilcox Canada

## THERMALUME DOOR MODEL T200-A

The Thermatite product line is stocked in over 100 door system manufacturing centres globally.

### Product Specifications

#### Sections:

Insulated sections fabricated from prepainted, aluminium sheet; with rigid polyurethane insulation core, CFC-11 free, face sheet stucco-embossed and rib reinforced.

Sections thermally broken, alum- polyurethane-alum sandwich formed by continuous process.

Sections formed with ship lap joint.

1.6mm (16ga) galvanized steel endcaps.

Face sheet thickness: T200-A 0.0256"

Section thickness: T200-A 51mm (2")

#### Reinforcement:

Continuous internal reinforcement for hardware mounting.

#### Weatherstripping:

Neoprene bulb weatherstrip with continuous aluminum retainer full width of bottom of door.

Dual seals between sections.

#### Finish:

Two coat, baked-on paint system on exterior side, primer and polyester finish coat. (White)

#### Hardware:

[Refer to hardware page. Click HERE to view clearance charts and hardware specifications.](#)

#### Design:

Door design to meet industry-standard windload.

### OPTIONS FOR THERMALUME T200-A

#### Thermal Glazing in high impact polystyrene frame:

610mm X 150mm (24" X 6")

610mm X 200mm (24" X 8")

610mm X 305mm (24" X 12")

865mm X 405mm (34" X 16")

610mm X 305mm (24" X 12") dual acrylic

#### OTHER OPTIONS: T200-A

Combination PVC step plate and lift handle.

Exhaust port 75mm(3") or 100mm (4") diameter.

Neoprene top weatherstrip for full width of door.

Full height thermal break and anti- friction strip for galvanized endcaps.

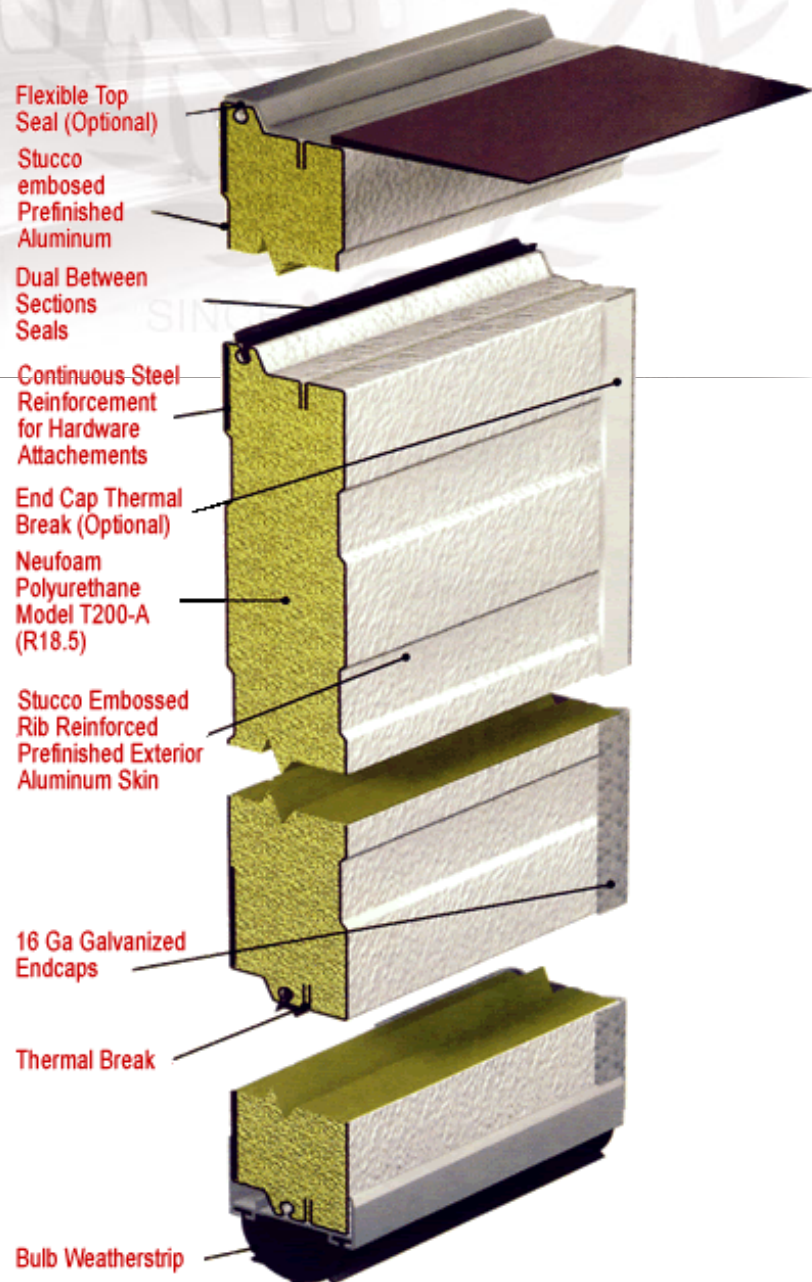

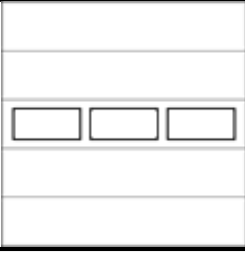
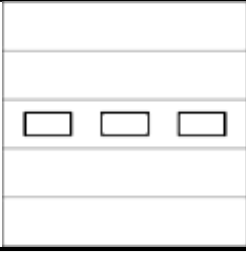
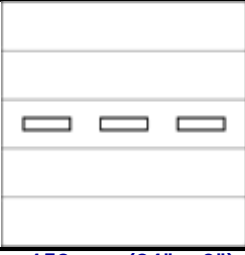
Full Vision	Type D	Type E	Type B & CPL
			
<p>Full Vision glazing section with 12.7 (1/2") thick insulating glass, finish white aluminium</p>	<p>Custom size 865 x 405mm (34" x 16") sealed glass unit set in moulded frame.</p>	<p>610 x 305mm (24" x 12") clear float glass sealed unit set in moulded frame.</p>	<p>B -610 x 152 mm (24" x 6") CPL - 610 x 203mm (24" x 8") clear float glass sealed unit set moulded frame.</p>